

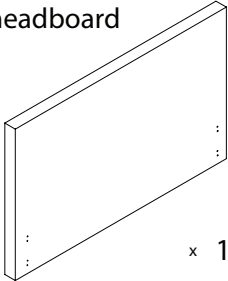

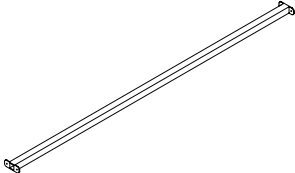



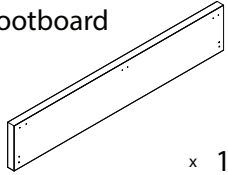
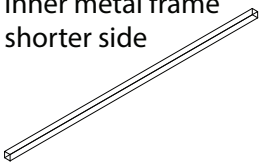
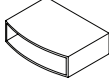
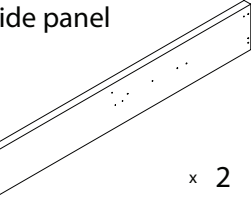
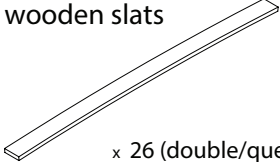
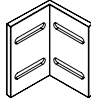
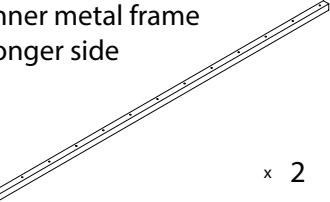
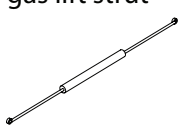
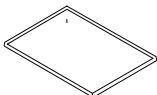
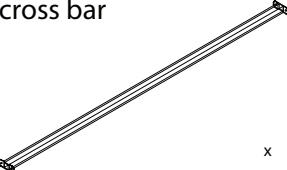
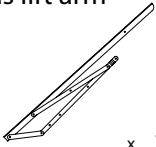

# Gas Lift Storage Bed Frame

## Installation Guide

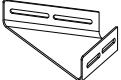
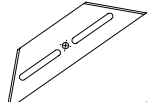
### COMPONENT LIST

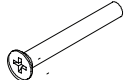
<b>headboard</b>  x 1	<b>middle support bar</b>  x 1 (double/queen) x 2 (king)	<b>double joining clip</b>  x 13 (double/queen) x 26 (king)
<b>footboard</b>  x 1	<b>inner metal frame shorter side</b>  x 2	<b>single end clip</b>  x 26
<b>side panel</b>  x 2	<b>wooden slats</b>  x 26 (double/queen) x 39 (king)	<b>metal bracket A</b>  x 6
<b>inner metal frame longer side</b>  x 2	<b>gas lift strut</b>  x 2	<b>floor mat</b>  x 1
<b>cross bar</b>  x 1	<b>gas lift arm</b>  x 2	<b>plastic corner leg</b>  x 4 <b>sharp screw</b>  x 4
<b>metal bracket B</b>  x 2	<b>metal bracket C</b>  x 4	<b>short bolt</b> x 64 (double/queen) x 68 (king) <b>nut</b>  x 16 (double/queen) x 20 (king)
<b>plastic corner joiner</b>  x 4	<b>long bolt</b>  x 10 (double/queen) x 14 (king)	<b>support leg</b>  x 2 (double/queen) x 4 (king)

1

Using the 4 sharp screws, please attach the corner legs on either side of the headboard and footboard. It may help to use an electric screwdriver if present. Please install in preferred location by screwing into the board.

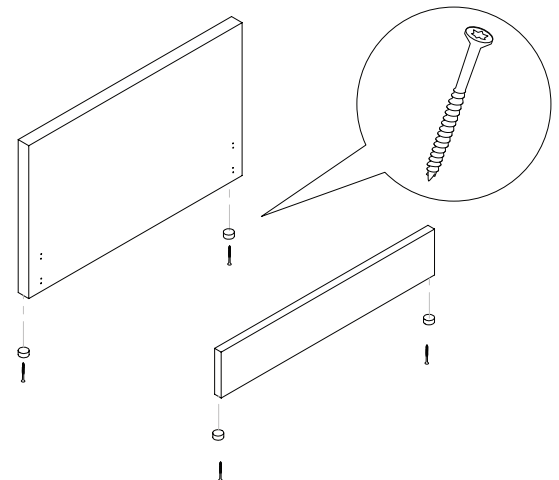

2

Attach the 2 side panels to the headboard using the short bolts and brackets A. Attach the foot panel to the side panels using short bolts and brackets A and B as shown below

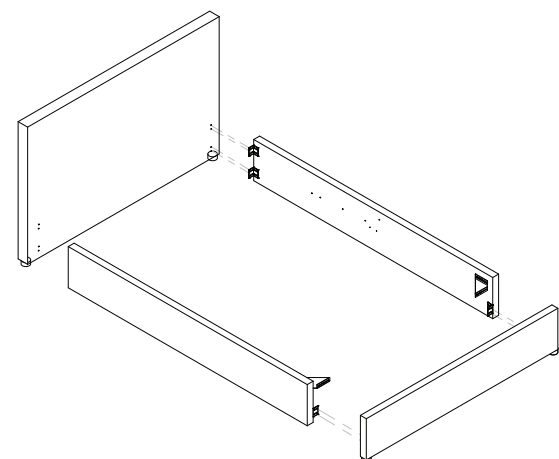

3

Attach the gas lift arms to the side panels using short bolts. Next, attach the gas lift struts to the arms. Then, use 2 nuts to secure the struts to the metal arms

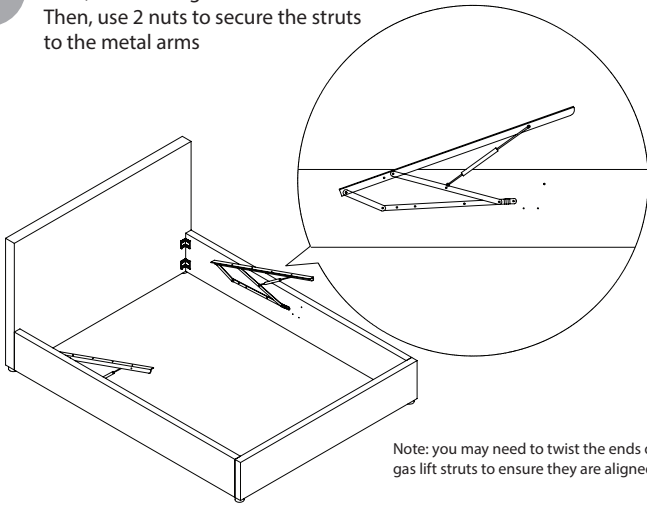

Note: you may need to twist the ends of the gas lift struts to ensure they are aligned.

4

Join the inner metal frame together. The 2 longer bars and the 2 shorter bars can be connected using the plastic corner joiners and secured using metal bracket C. Attach the middle bar to the inner frame as shown below. Secure everything using short bolts

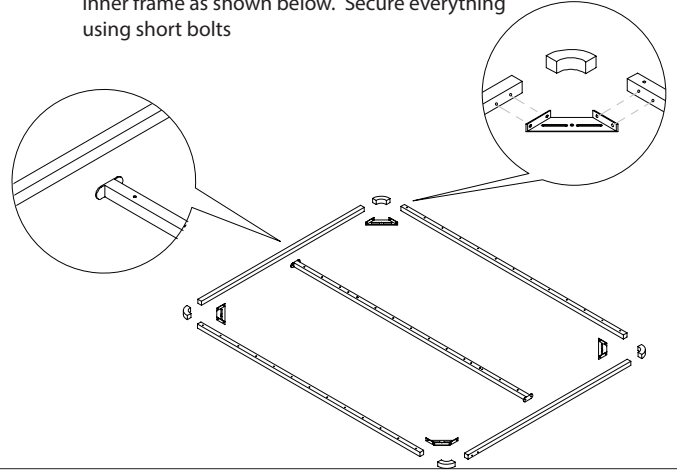

5

Attach the inner metal frame onto the 2 gas lift arms using the long bolts and nuts provided

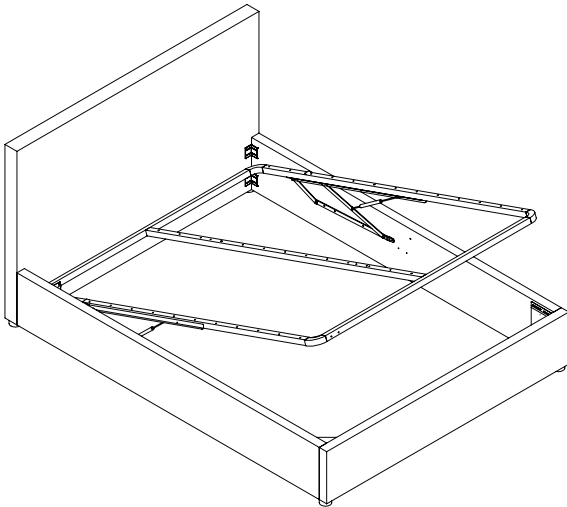

6

Attach the cross bar from the middle of the left side panel to the right side panel using short bolts

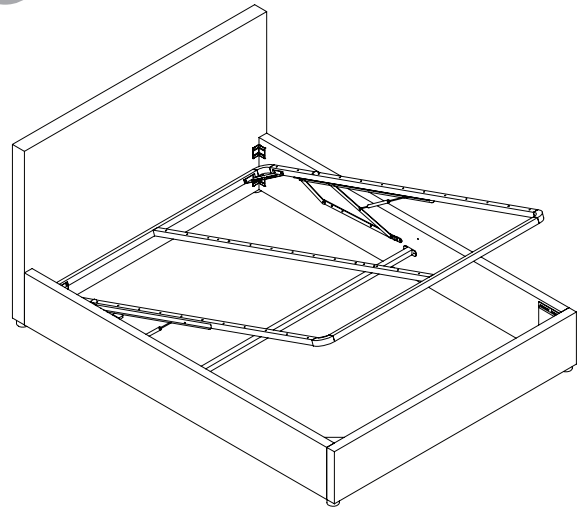

7

Fix the support legs underneath the middle bar using the long bolts and nuts provided

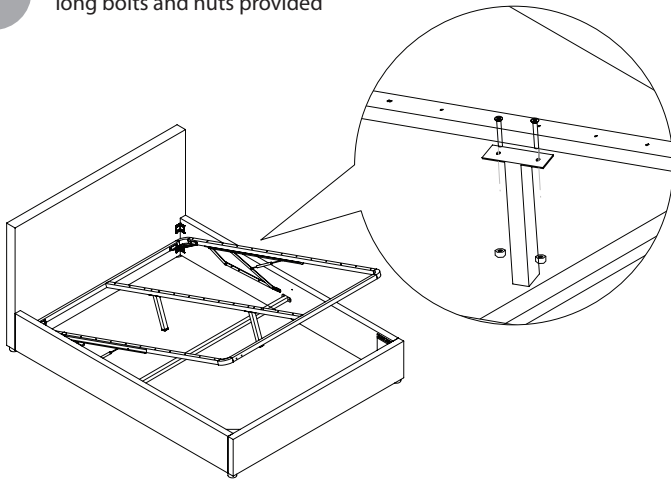

8

Lift up the bed and place the mat underneath\*

\*Please make sure only the very edges of the mat touches the 4 bottom sides of the bed frame. Otherwise you will find that the mat will be a couple cm too short on all sides

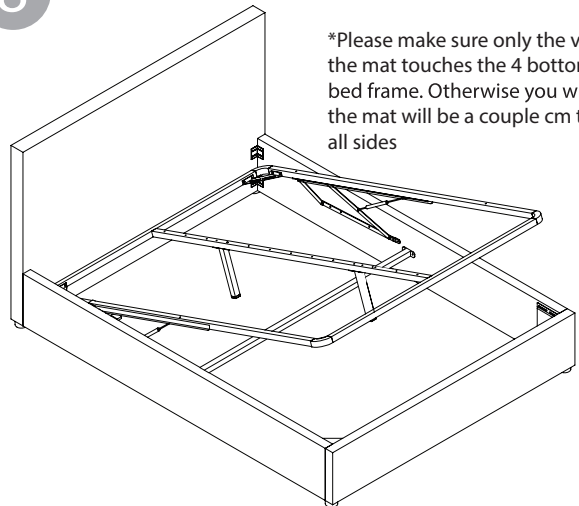

9

Press down on the inner frame until it is closed. You will need to use substantial force as there is no mattress sitting on top at this stage

Join the wooden slats using the middle and end plastic clips first

Once a row of slats is created, then position onto the metal frame and ensure it 'clicks' into place securely

