

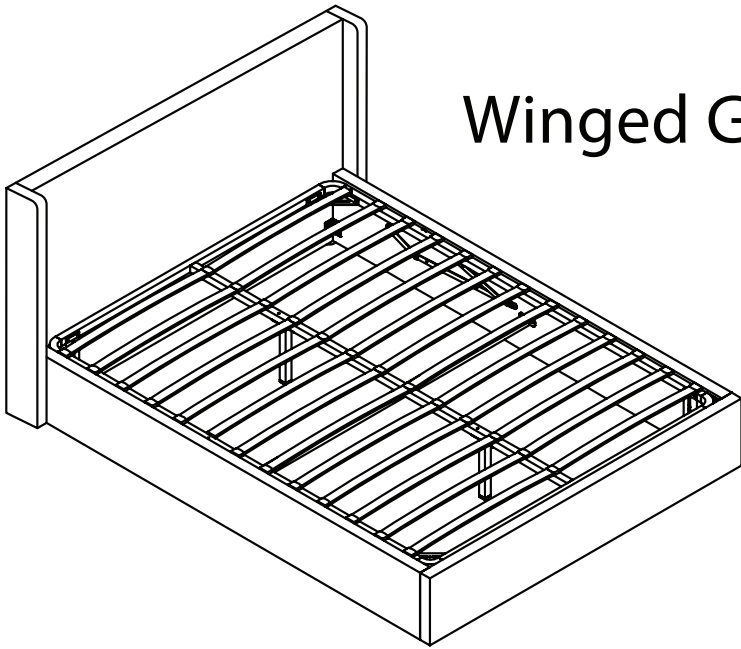

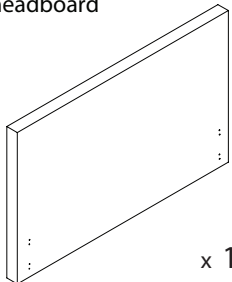

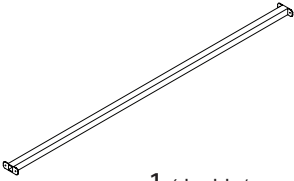





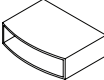
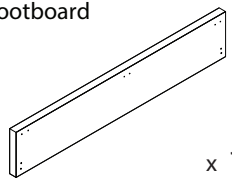
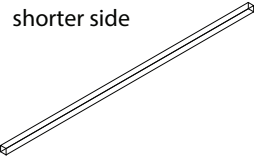

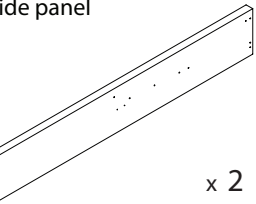
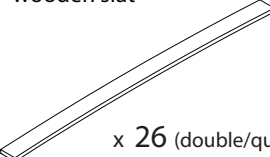
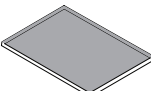
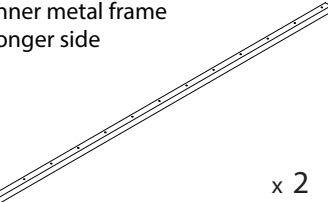
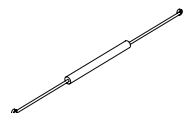
Winged Gas Lift Storage Bed Frame

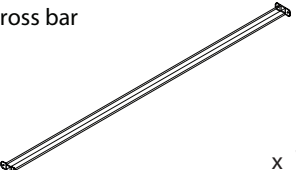
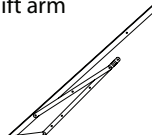
Installation Guide

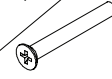

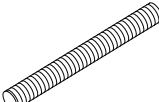
COMPONENT LIST

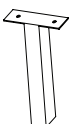
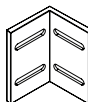
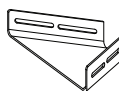
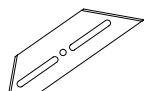
headboard  x 1	middle support bar  x 1 (double/queen) x 2 (king)	double joining clip  x 13 (double/queen) x 26 (king)
		single end clip  x 26
footboard  x 1	inner metal frame shorter side  x 2	wings  x 2
side panel  x 2	wooden slat  x 26 (double/queen) x 39 (king)	floor mat  x 1
inner metal frame longer side  x 2	gas lift strut  x 2	washer x 4  nut  x 16 (double/queen) x 20 (king)
cross bar  x 1	gas lift arm  x 2	short bolt x 64 (double/queen) x 68 (king)  x 10 (double/queen) x 14 (king) long bolt 
plastic corner joiner  x 4	headless bolt  x 4	wing nut  x 4
	support leg  x 2 (double/queen) x 4 (king)	metal bracket A  x 6
		metal bracket B  x 2
		metal bracket C  x 4

1 Attach 2x headless bolts to each wing. Unzip the back of headboard, and slide 2 wings on either side. Use wing nuts and washers to secure the wings

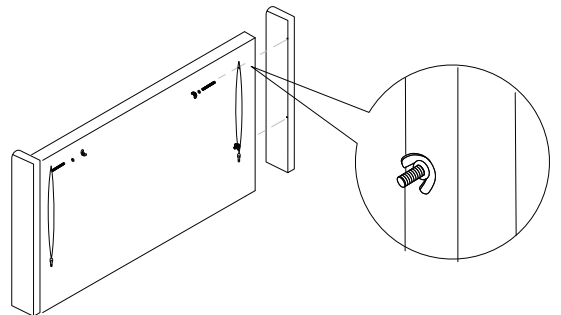

2 Attach the 2 side panels to the headboard using the short bolts and brackets A. Attach the foot panel to the side panels using short bolts and brackets A and B as shown below

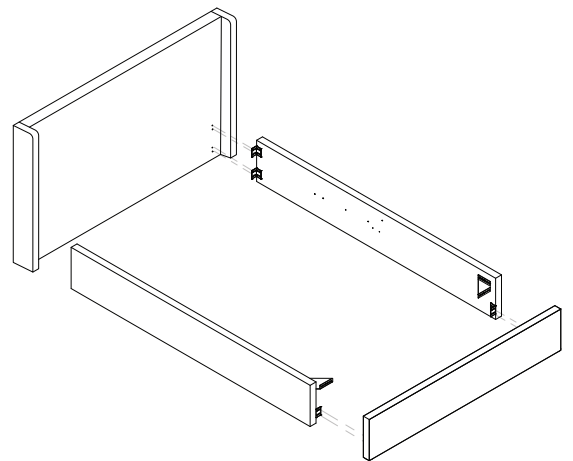

3

Attach the gas lift arms to the side panels using short bolts. Next, attach the gas lift struts to the arms. Then, use 2 nuts to secure the struts to the metal arms

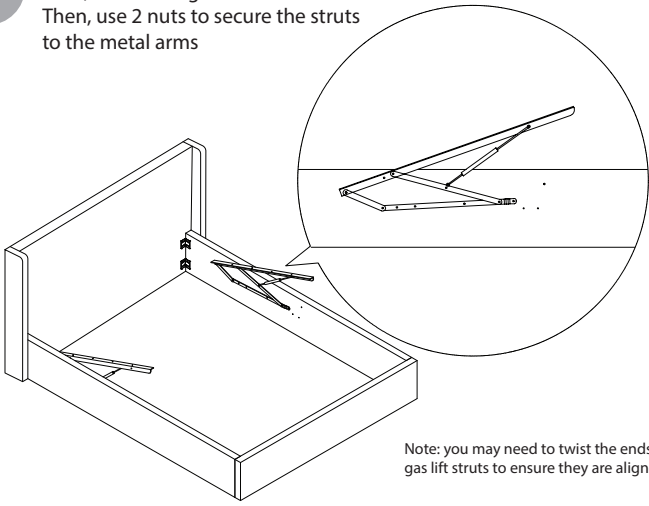

Note: you may need to twist the ends of the gas lift struts to ensure they are aligned.

4

Join the inner metal frame together. The 2 longer bars and the 2 shorter bars can be connected using the plastic corner joiners and secured using metal bracket C. Attach the middle bar to the inner frame as shown below. Secure everything using short bolts

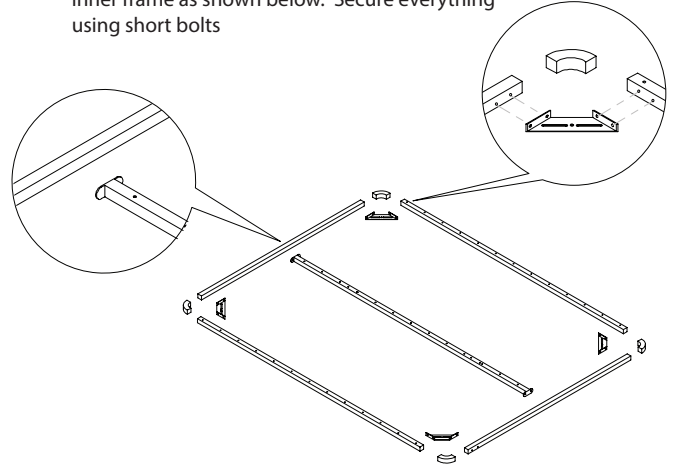

5

Attach the inner metal frame onto the 2 gas lift arms using the long bolts and nuts provided

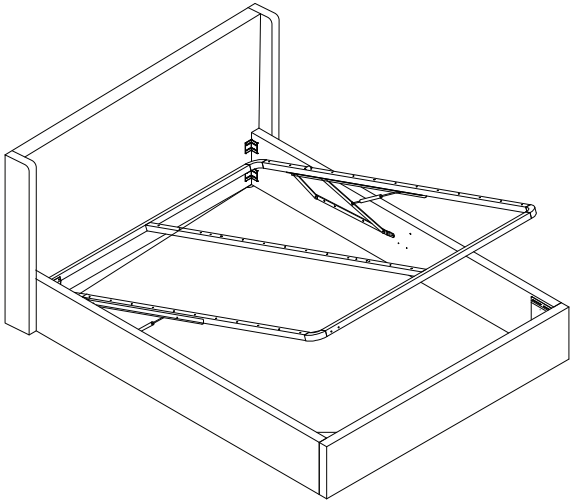

6

Attach the cross bar from the middle of the left side panel to the right side panel using short bolts

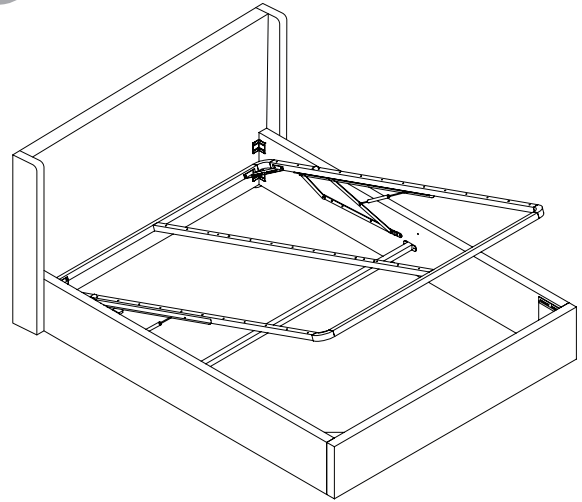

7

Fix the support legs underneath the middle bar using the long bolts and nuts provided

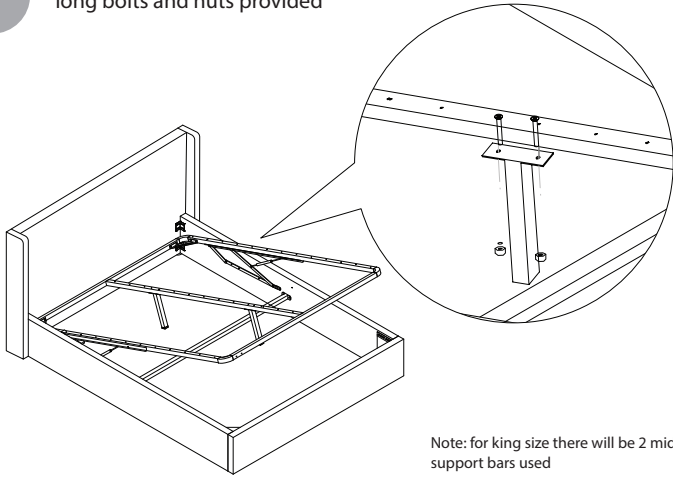

Note: for king size there will be 2 middle support bars used

8

Lift up the bed and place the mat underneath

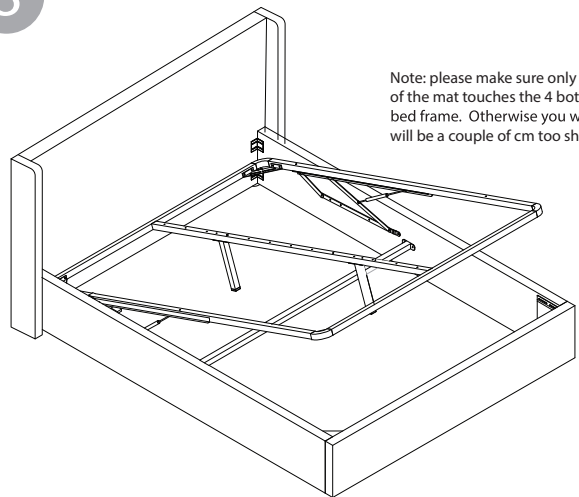

Note: please make sure only the very edges of the mat touches the 4 bottom sides of the bed frame. Otherwise you will find that the mat will be a couple of cm too short on all sides

9

Press down on the inner frame until it is closed. You will need to use substantial force as there is no mattress sitting on top at this stage

Join the wooden slats using the middle and end plastic clips. Once a row of slats are created, position them onto the metal frame and ensure it 'clicks' into place securely

